

# DriftTrak® DTSLB

Bypass Slab

## Material Composition

**DTSLB Clip Material:** ASTM A1003/A1003M Structural Grade 50 (340) Type H, ST50H (ST340H): 50ksi (340MPa) minimum yield strength, 65ksi (450MPa) minimum tensile strength, 68mil minimum thickness (14 gauge, 0.0713" design thickness) with ASTM A653/A653M G90 (Z275) hot dipped galvanized coating.

**DTSLB-HD Clip and Track Material:** ASTM A1003/A1003M Structural Grade 50 (340) Type H, ST50H (ST340H): 50ksi (340MPa) minimum yield strength, 65ksi (450MPa) minimum tensile strength, 97mil minimum thickness (12 gauge, 0.1017" design thickness) with ASTM A653/A653M G60 (Z180) hot dipped galvanized coating.

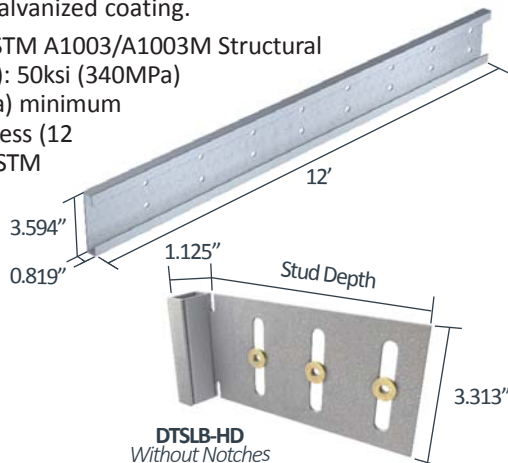
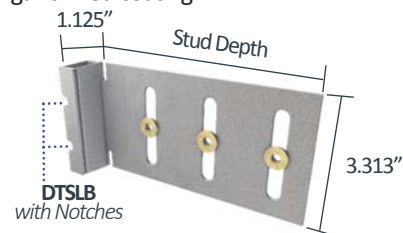

US Patent #7,503,150

## DriftTrak DTSLB Allowable (Unfactored) Loads<sup>1</sup>

DriftTrak® DTSLB & DTSLB-HD, Recommended Allowable Load (lbs): F2									
Stud		Fastener Pattern 1 & 2							
		DTSLB				DTSLB-HD			
		8" Fastener Spacing in Track to Structure (or welded on each side)		16" Fastener Spacing in Track to Structure (or welded on each side)		8" Fastener Spacing in Track to Structure (or welded on each side)		16" Fastener Spacing in Track to Structure (or welded on each side)	
Thickness Mils (ga)	Yield Strength (ksi)	w/2 #12 Screws	w/3 #12 Screws	w/2 #12 Screws	w/3 #12 Screws	w/2 #12 Screws	w/3 #12 Screws	w/2 #12 Screws	w/3 #12 Screws
33 (20)	33	377	565	377	565	377	565	377	565
33 (20)	50	544	808	544	753	544	817	544	817
43 (18)	33	561	808	561	753	561	841	561	841
43 (18)	50	808	808	753	753	810	1,215	810	953
54 (16)	33	789	808	753	753	789	1,183	789	953
54 (16)	50	808	808	753	753	1,139	1,618	953	953
68 (14)	50	808	808	753	753	1,610	1,618	953	953
97 (12)	50	808	808	753	753	1,618	1,618	953	953
<b>Maximum Allowable Clip Load</b>		<b>808</b>		<b>753</b>		<b>1,618</b>		<b>953</b>	

## Notes:

- Design loads are for attachment of DriftTrak DTSLB to stud only. Load tables reflect horizontal loads (F2).
- Attachment to structure engineered by others.
- Allowable loads have not been increased for wind, seismic, or other factors.
- #12 screws are provided with each step bushing for attachment to stud. Load requirements don't always justify use of a third screw.
- Clips are manufactured to fit into the DriftTrak and provide up to 2" of vertical deflection (1" up and 1" down), and free lateral movement of the structure.
- Allow a minimum of 0.875" from the structure to the inside flange of the bypassing stud to allow for track attachment. Standard offset of stud from the open face of the track should not exceed 1.25".
- One row of bridging is recommended at a maximum distance of 18" from DriftTrak to resist torsional effects.

<sup>1</sup> For LRFD Design Strengths refer to ICC-ESR-2049.

## Nomenclature

DriftTrak DTSLB is classified by multiplying stud depth by 100, followed by "HD," based on F2 strength required. Refer to load tables.\*

**Example:** 6" stud depth, with an outward load (F2) of 1,000 lbs

**Designate:** DriftTrak® DTSLB600-HD

\* Notches are standard in DriftTrak DTSLB. For greater F2 outward load capacity, use DTSLB-HD clips w/o notches. Refer to Allowable Load Table.

## Load Direction

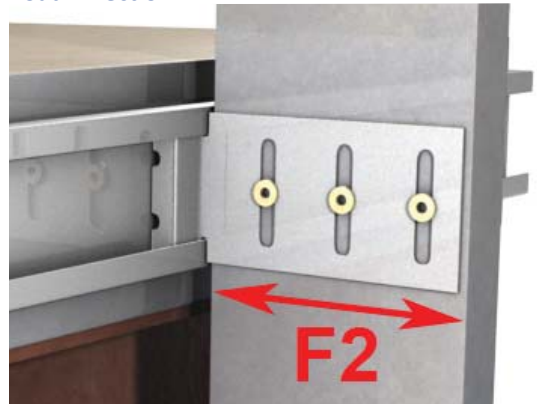

**Fastener Patterns**

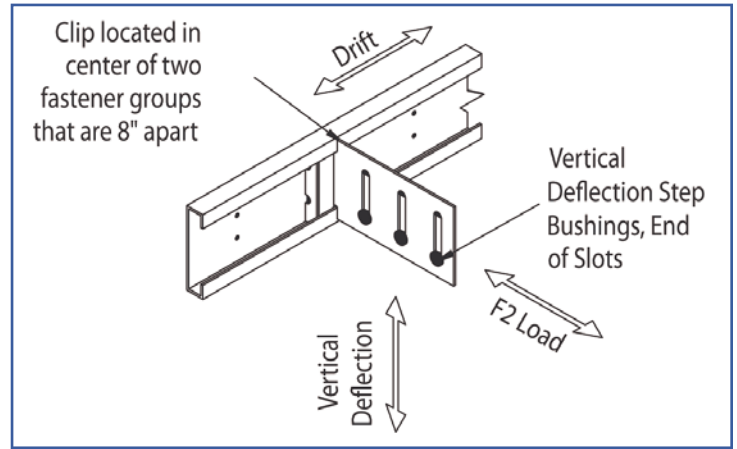
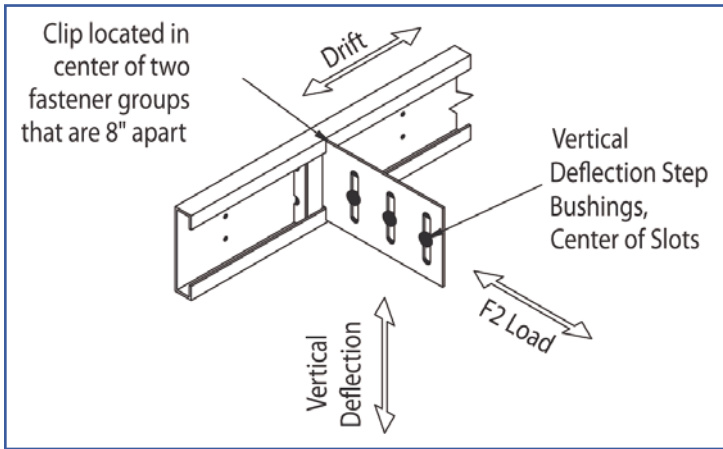

**Fastener Pattern 1** replicates a condition of out-of-plane wind or seismic force with no vertical live load deflection and full in-plane drift.

**Fastener Pattern 2** replicates a condition of out-of-plane wind or seismic force with full vertical live load deflection and full in-plane drift.

**Locking of Lateral Movement After Panel Installation**

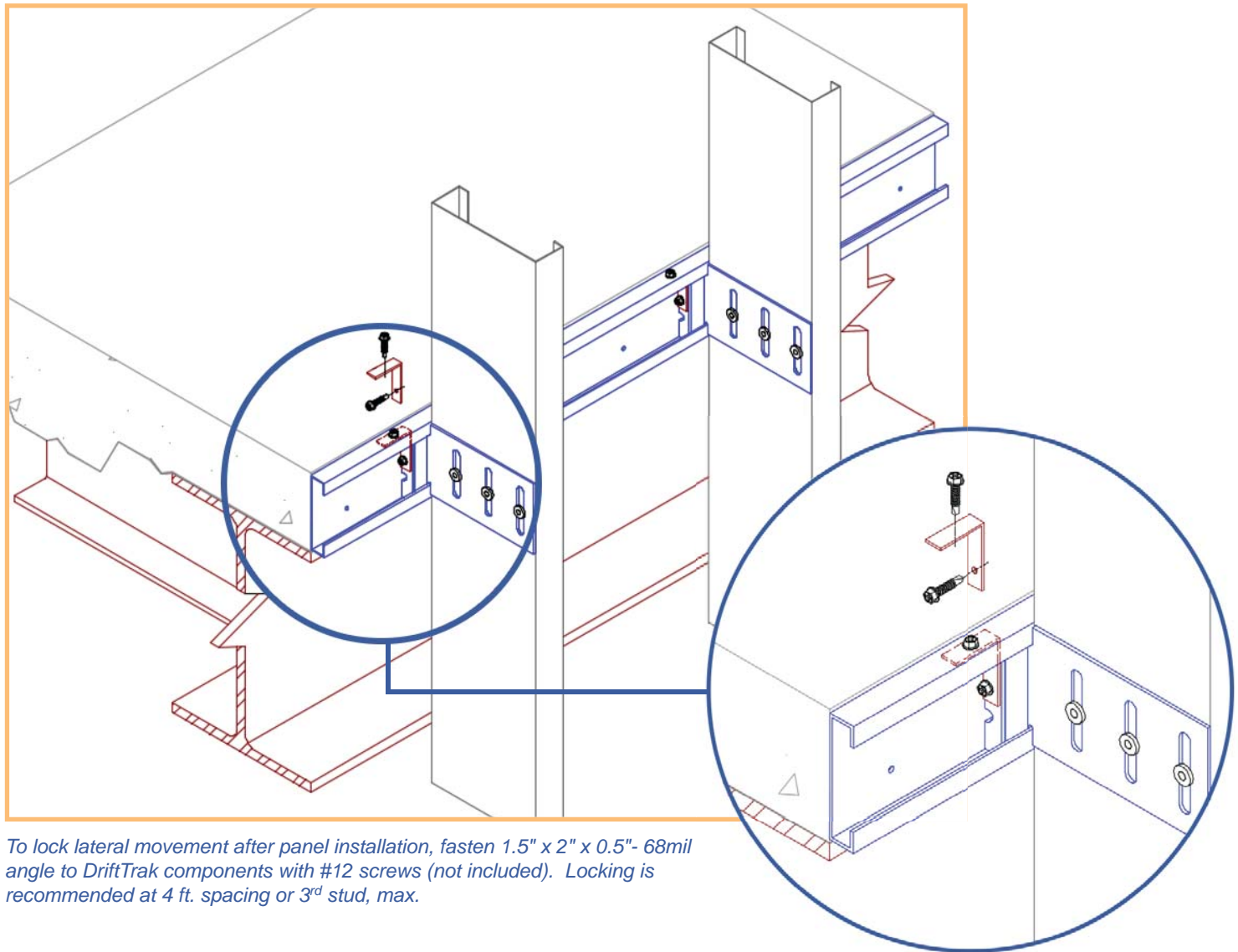

To lock lateral movement after panel installation, fasten 1.5" x 2" x 0.5"- 68mil angle to DriftTrak components with #12 screws (not included). Locking is recommended at 4 ft. spacing or 3<sup>rd</sup> stud, max.

**ICC ES**  
 DriftTrak DTSLB362/400,  
 DTSLB600 & DTSLB800  
 ICC-ESR-2049  
 www.icc-es.org

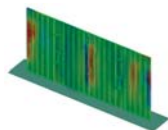

DriftTrak DTSLB Series  
 Blast and Seismic Design data  
 www.steelnetwork.com

\*\* For more information or to review a copy of each of these reports, please visit our website at <http://www.steelnetwork.com/Site/TechnicalData>