

# DriftTrak® DTLB

Bypass Slab

## Material Composition

**Clip Material:** ASTM A1003/A1003M Structural Grade 50 (340) Type H, ST50H (ST340H): 50ksi (340MPa) minimum yield strength, 65ksi (450MPa) minimum tensile strength, 97mil minimum thickness (12 gauge, 0.1017" design thickness) with ASTM A653/A653M G90 (Z275) hot dipped galvanized coating.

**Track Material:** ASTM A1003/A1003M Structural Grade 50 (340) Type H, ST50H (ST340H): 50ksi (340MPa) minimum yield strength, 65ksi (450MPa) minimum tensile strength, 97mil minimum thickness (12 gauge, 0.1017" design thickness) with ASTM A653/A653M G60 (Z180) hot dipped galvanized coating.

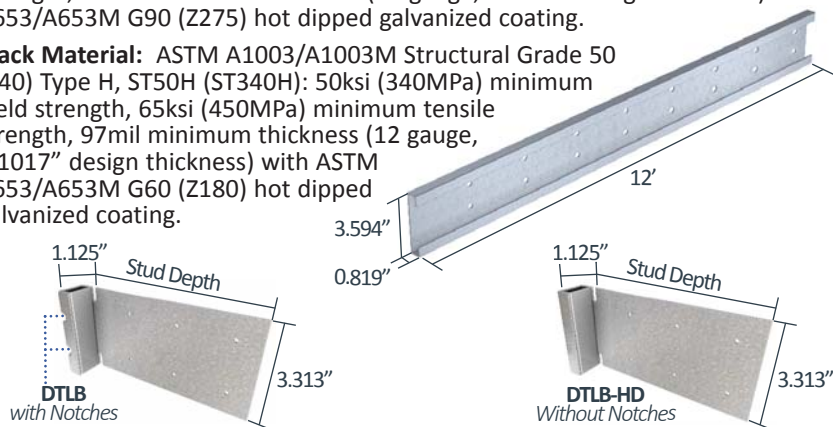

## DriftTrak DTLB Allowable (Unfactored) Loads

DriftTrak® DTLB & DTLB-HD, Recommended Allowable Load (lbs): F2 & F3									
Stud		F2 Allowable Loads				F3 Allowable Loads			
		DTLB600 & DTLB800 <i>with Notches</i>		DTLB600-HD & DTLB800-HD <i>without Notches*</i>		DTLB600 & DTLB600-HD <i>Total Offset = 0.819" + 1" gap</i>		DTLB800 & DTLB800-HD <i>Total Offset for 8" Studs = 0.819" + 1.0" gap Total Offset for 6" Studs = 0.819" + 2.0" gap</i>	
Thickness Mils (ga)	Yield Strength (ksi)	w/4 #12 Screws	w/6 #12 Screws	w/4 #12 Screws	w/6 #12 Screws	w/4 #12 Screws	w/6 #12 Screws	w/4 #12 Screws	w/6 #12 Screws
33 (20)	33	762	808	754	1,130	258	308	226	264
33 (20)	50	808	808	1,089	1,633	373	446	327	381
43 (18)	33	808	808	1,122	1,682	384	460	336	393
43 (18)	50	808	808	1,620	1,707	555	664	486	567
54 (16)	33	808	808	1,577	1,707	540	647	473	552
54 (16)	50	808	808	1,707	1,707	780	934	683	797
68 (14)	50	808	808	1,707	1,707	1,103	1,320	966	1,127
97 (12)	50	808	808	1,707	1,707	1,163	1,392	1,019	1,189
<b>Max Allowable Clip Load</b>		<b>808</b>		<b>1,707</b>		<b>1,750</b>		<b>1,272</b>	

## Notes:

- Allowable load tables incorporate eccentric loading of fasteners.
- Loads listed reflect force in a single direction. When multiple loads react on the connection, it is the responsibility of the designer to check the interaction of forces.
- Torsional effects are considered on screw group for F3 allowable loads. It is assumed that all of the torsional moment is taken by the connection to the stud.
- Design loads are for attachment of DriftTrak DTLB to stud only. Load tables reflect horizontal loads (F2) and vertical loads (F3)
- Use 8" fastener spacing in track to structure (or weld on each side of track). Size of fasteners or weld is engineered by others.
- Allowable loads have not been increased for wind, seismic, or other factors.
- Clips are manufactured to fit into the DriftTrak and provide a rigid connection to the stud, and free lateral movement of the structure.
- Allow a minimum of 0.875" from the structure to the inside flange of the bypassing stud to allow for track attachment.
- One row of bridging is recommended at a maximum distance of 18" from DriftTrak to resist torsional effects.

## Nomenclature

DriftTrak DTLB is classified by multiplying stud depth by 100, followed by "HD," based on F2 strength required. Refer to load tables.\*

**Example:** 6" stud depth, with an outward load (F2) of 1,000 lbs

**Designate:** DriftTrak® DTLB600-HD

\* Notches are standard in DriftTrak DTLB. For greater F2 outward load capacity, use DTLB-HD clips w/o notches. Refer to Allowable Load Table.

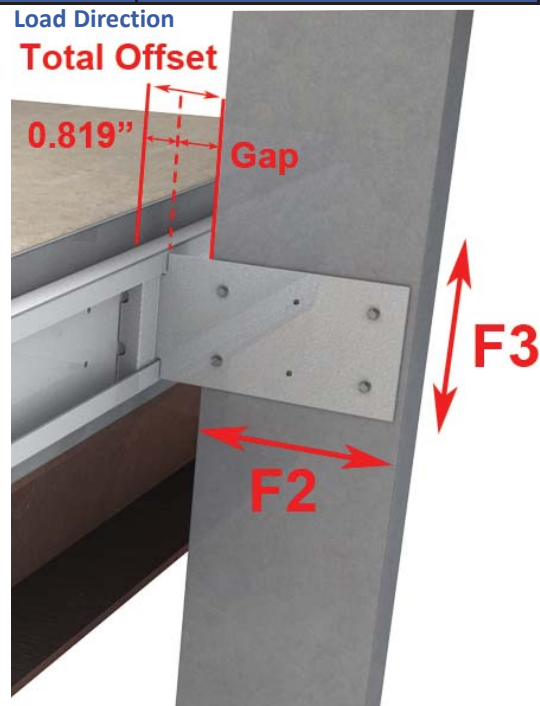

### Fastener Patterns

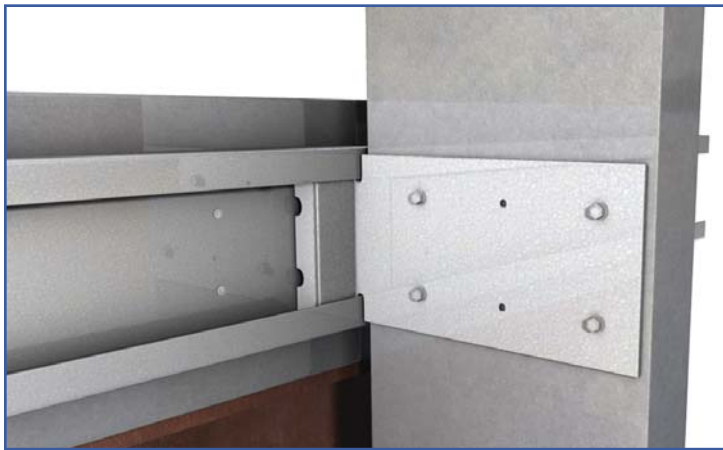

4 Hole Fastener Pattern



6 Hole Fastener Pattern

### Locking of Lateral Movement After Panel Installation

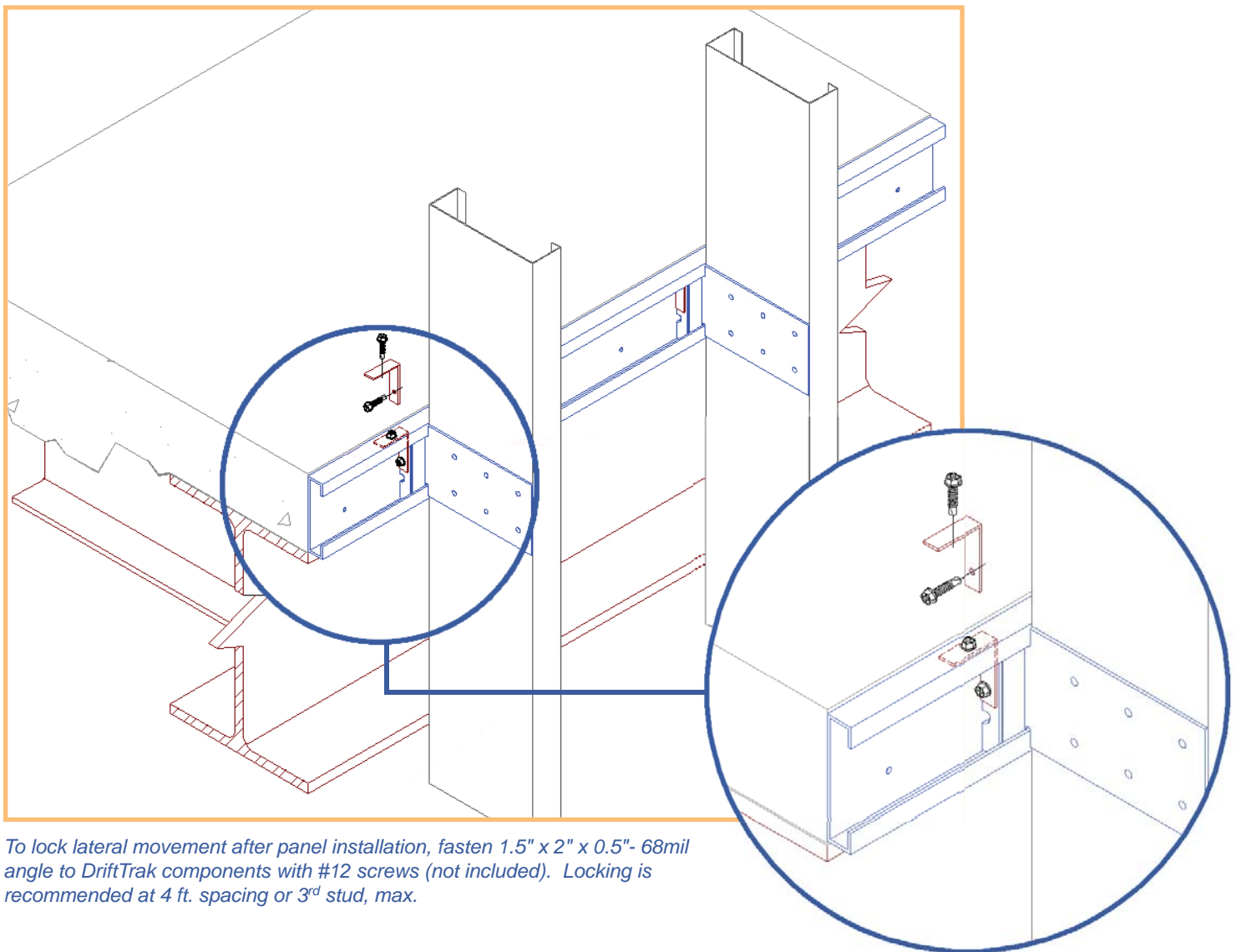

To lock lateral movement after panel installation, fasten 1.5" x 2" x 0.5"- 68mil angle to DriftTrak components with #12 screws (not included). Locking is recommended at 4 ft. spacing or 3<sup>rd</sup> stud, max.

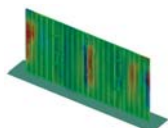

DriftTrak DTLB Series  
Blast and Seismic Design data  
[www.steelnetwork.com](http://www.steelnetwork.com)

\*\* For more information or to review a copy of this report, please visit our website at <http://www.steelnetwork.com/Site/TechnicalData>